

Route Sketch
SCALE 1:250 000

NOTE:

- There are no residences within 1.6 km of 5-10 (surface) well location.**
- Nearest Occupied Residence - ± 11.7 km East (Peco Inn)**
- Nearest Recreation Area - ± 0.4 km Elk River Camp Ground**

- Nearest Urban Center - Lodgepole - ± 56 km North East**
- Nearest Surface Development - ± 11.7 km East (Peco Inn)**

NOTE :

- THE PROPOSED WELL IS :
- AT LEAST 1.50 km FROM THE CORPORATE LIMITS OF A CITY, TOWN OR VILLAGE. YES NO
 - OUTSIDE ANY POTENTIAL COAL DEVELOPMENT AREA. YES NO
 - AT LEAST 100 m FROM THE NORMAL HIGH WATER MARK OF ANY SIGNIFICANT WATER BODIES. YES NO
 - AT LEAST 100 m FROM ANY SURFACE IMPROVEMENTS. YES NO
 - AT LEAST 40 m FROM ANY SURVEYED ROAD. YES NO
 - AT LEAST 5.0 km FROM A LIGHTED AIRPORT. YES NO
 - AT LEAST 1.6 km FROM AN UNLIGHTED AIRPORT. YES NO
 - OUTSIDE A DESIGNATED SIGNIFICANT HISTORICAL SITE AREA. YES NO
 - EXPECTED TO ENCOUNTER ONLY HYDROCARBONS THAT ARE ESSENTIALLY FREE OF H₂ S. YES NO

THERE ARE NO SURFACE OR UNDERGROUND IMPROVEMENTS WITHIN 200 m OF WELL LOCATION, EXCEPT AS SHOWN.

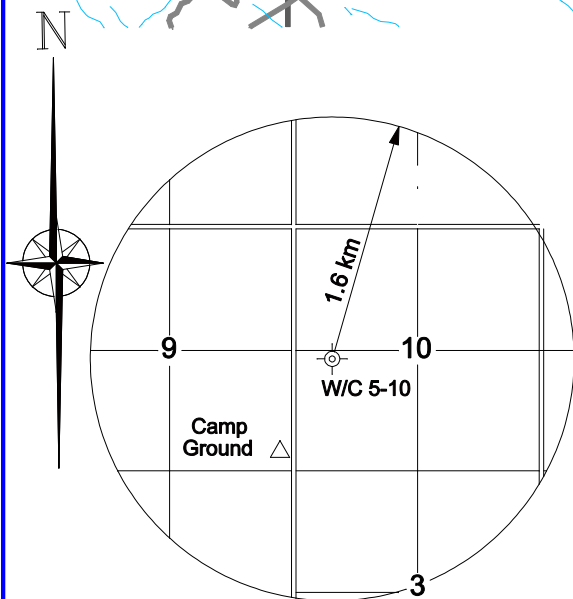

Residence Sketch
SCALE 1:50 000

Plan Showing Survey of Directional Drill Well Site and Access Road

BLAZE et al BRAZEAU RIVER 5-10-46-15

from a Surface Location in
L.S. 5 Sec. 10 Twp.46 Rge.15 W.5th Mer.
Yellowhead County

I, R. KEVIN JONES, ALBERTA LAND SURVEYOR, OF CALGARY ALBERTA, CERTIFY THAT THE SURVEY REPRESENTED BY THIS PLAN IS TRUE AND CORRECT TO THE BEST OF MY KNOWLEDGE, HAS BEEN CARRIED OUT IN ACCORDANCE WITH THE PROVISIONS OF THE ALBERTA LAND SURVEYORS ASSOCIATION MANUAL OF STANDARD PRACTICE, AND WAS COMPLETED ON THE 11th DAY OF MAY, 2007.

ALBERTA LAND SURVEYOR

WITNESS - GIRMA B. WORKU

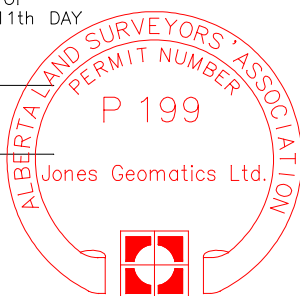

OPERATOR :
BLAZE ENERGY LTD.

ELEVATIONS:

SURFACE WELL LOCATION 5-10 = 1144.99

N.COR.: 1147.33

N.W. COR.: 1146.33 N.E. COR.: 1145.30

S.W. COR.: 1137.30 S.E. COR.: 1145.34

S. COR.: 1140.67

ELEVATION DATUM : ASCM 344549 Elev.= 1231.44

SURFACE

LOCAL CO-ORDINATES:

740.89 N. of S. Boundary } Theor. Sec.10
244.23 E. of W. Boundary }

TOTAL CO-ORDINATES:

12086.76m North } N.E.33-44-15-W.5M.
264.35m East }

AREAS :

WELL SITE = 1.487 ha. 3.67 Ac.
ACCESS ROAD = 0.040 ha. 0.10 Ac.
TOTAL = 1.527 ha. 3.77 Ac.

Plan #: _____

Version: _____

File: _____

Technical Services

No.	DESCRIPTION	DATE
REVISION TABLE		



Jones Geomatics Ltd.

FILE: NC4003-07